

- w** Ideal for mixing, kneading and dispersion of very viscous doughs and pastes.
- w** Heavy duty, robust, Z (Sigma) Blade tilting mixers for production and pilot plant.

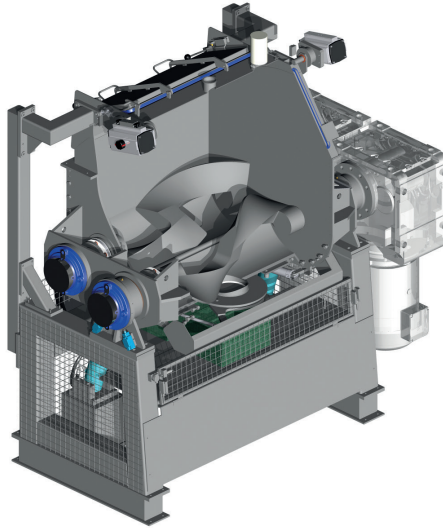

“ We have used **Winkworth** machines for over 10 years and currently have two Z Blade mixers used for mixing ceramic powders and carbon materials into a homogeneous mix. The **Winkworth** Z mixer is the most efficient type of mixer on the market for mixes that require heavy mixing. ”

**Winkworth** Z Blade mixers are used in a wide range of industries and applications, including:

Chewing/bubble gum  
Sugar pastes  
Biscuit doughs  
Adhesives  
Metal powders

Sealants  
Mastics  
Soaps  
Detergents  
Silicone rubbers

Pharmaceuticals  
Welding materials  
Energetics  
Brake linings  
Confectionery

Rubber solutions  
Abrasives  
Fibreglass doughs  
Ceramics  
Roof tiles

Winkworth Machinery Ltd  
Mixer House  
Stroudley Road, Basingstoke  
Hampshire RG24 8FW



**Mixing all ways** 

- w Highly efficient **Winkworth** cast profile twin blade design.
- w Extruder discharge Z Blade mixers are available with hydraulic or electric drives.

Features	Std	Option	Sizes
Fabricated in stainless steel	✓		20 litre to 1800 litre working volume (MZ20 to MZ1800)
Support provided by fully welded box section frames	✓		
Split gland housings for easy maintenance	✓		
Hydraulic tilt or discharge	✓		
Bottom outlet discharge		●	
Extruder discharge		●	
Integrated rigid lid for automation		●	
Heating / Cooling jacket		●	
Hardened steels, wear blades for abrasive mixes		●	
Heavy duty models for stiffer products		●	
Vacuum models for drying or de-aerating		●	
ATEX certified models		●	
Liquid additions		●	
Laboratory models (refer to Lab Z)		●	
Variable speed drives		●	

At **Winkworth** we design each machine to suit your specific needs. The abbreviated option chart (above) is a guide to assist with developing the specification of your machine. To get your project started please call our sales team who will be delighted to help you.



**Winkworth** are application specialists in the complex and challenging world of mixing. Since 1924, years of experience, knowledge and client feedback have enabled **Winkworth** to design and manufacture bespoke mixing machinery for almost every mixing need.

**Winkworth's** current range includes the expertise and products originating from BPT Skerman and Premier Colloid Mills. For high shear in-line mixing we offer Ystral products and for low shear we have the Lindor "gentle touch" rotary drum blenders.

This complements the extensive range of proprietary mixer designs which are extensively used across all industries for mixing stiff gums, pastes, powders, liquids, etc, most of which are available at our Mixing Test Centre at our Basingstoke HQ.